



2.11.1
Línie
rezať
odstrániť
okraj
rezať



2.11.2
Výrez
ne rezať
odstrániť
okraj
rezať



3
3.11.1
Výrez
rezať
odstrániť
okraj
rezať



3.11.2
Výrez
rezať
odstrániť
okraj
rezať



9
3.11.3
Výrez
rezať
odstrániť
okraj
rezať



9.11.1
Výrez
rezať
odstrániť
okraj
rezať



2.11.1
Línie
rezať
odstrániť
okraj
rezať



2.11.2
Výrez
ne rezať
odstrániť
okraj
rezať



3.11.1
Výrez
rezať
odstrániť
okraj
rezať



3.11.2
Výrez
rezať
odstrániť
okraj
rezať



9.11.1
Výrez
rezať
odstrániť
okraj
rezať



9.11.2
Výrez
rezať
odstrániť
okraj
rezať

1

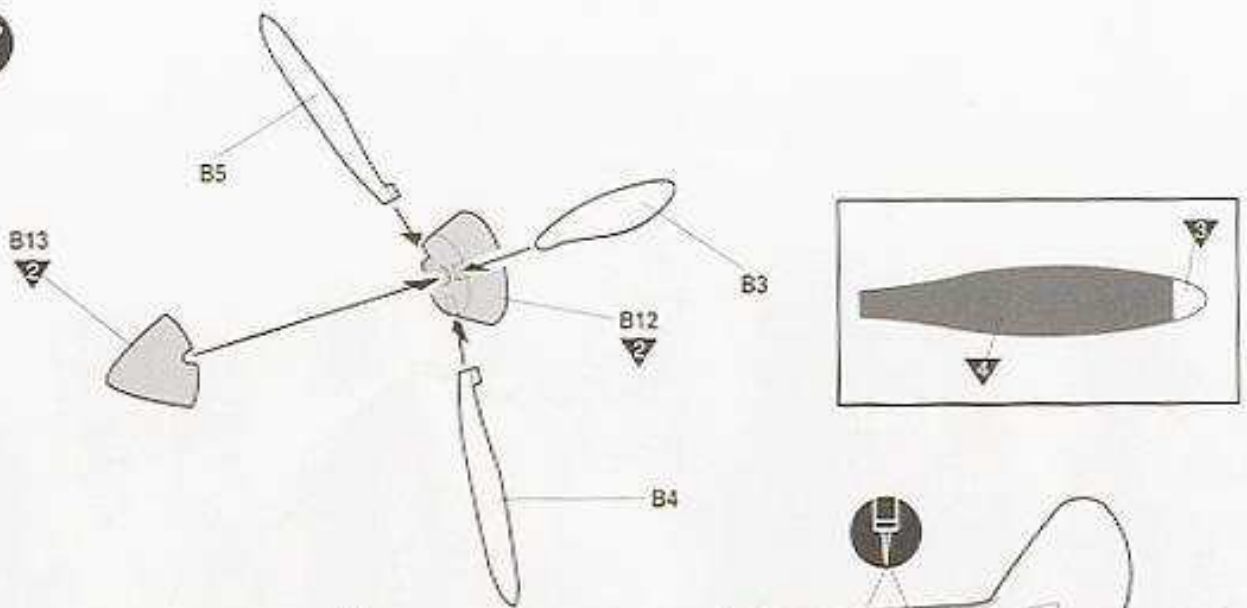

2

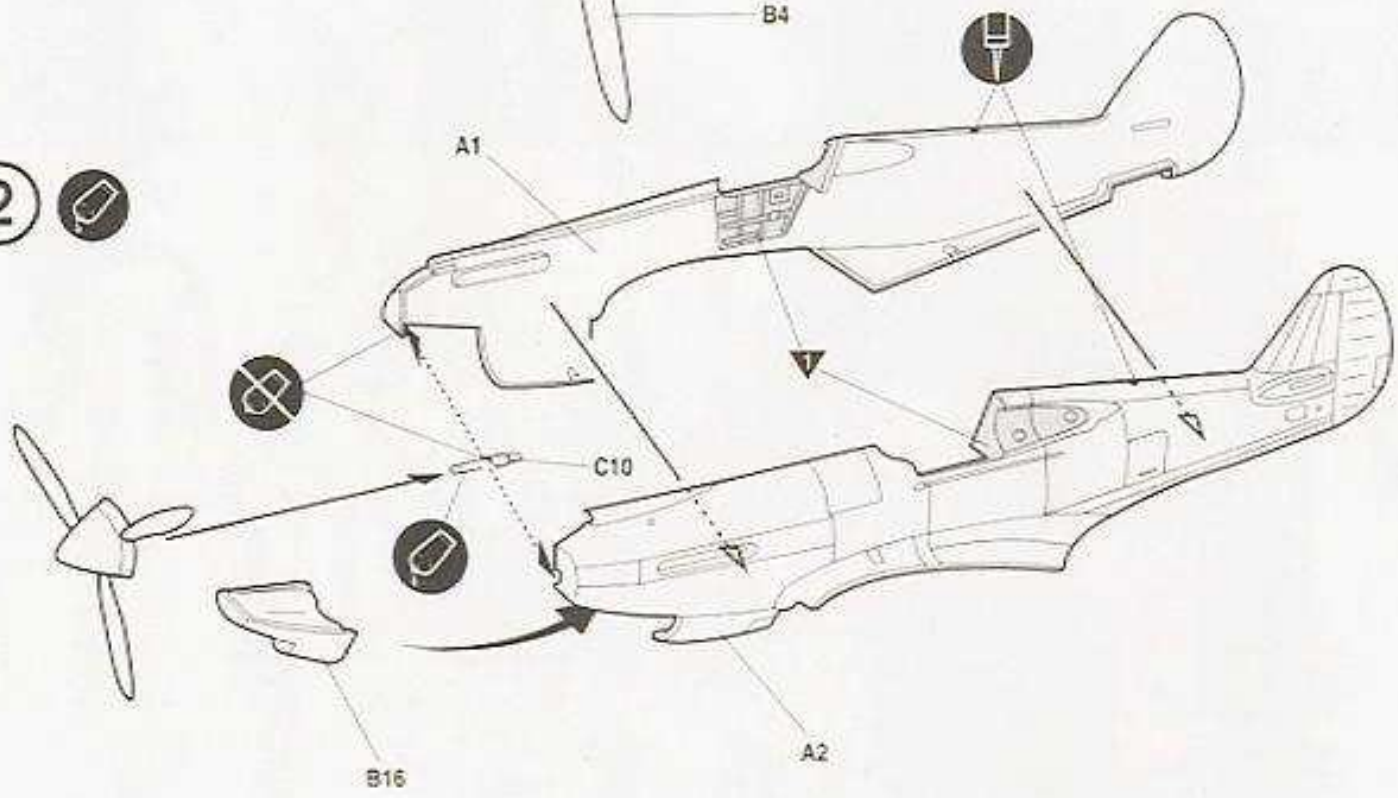

3

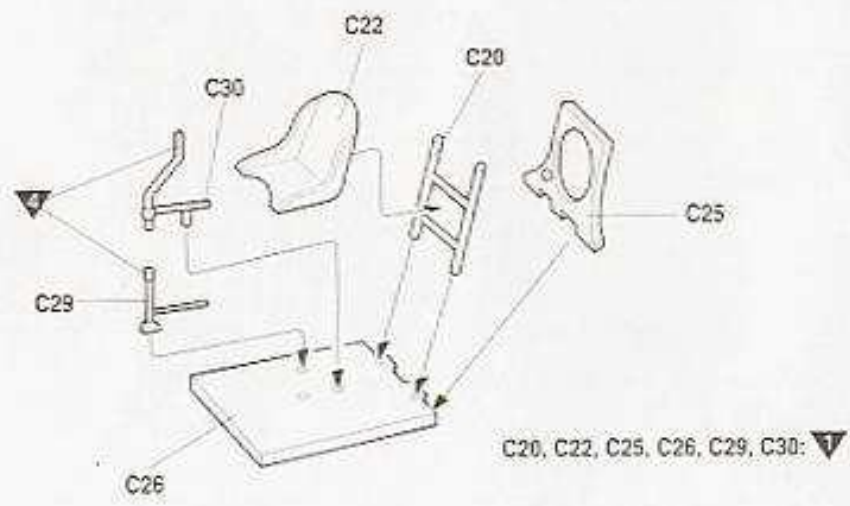

C20, C22, C25, C26, C29, C30: ▽

4 

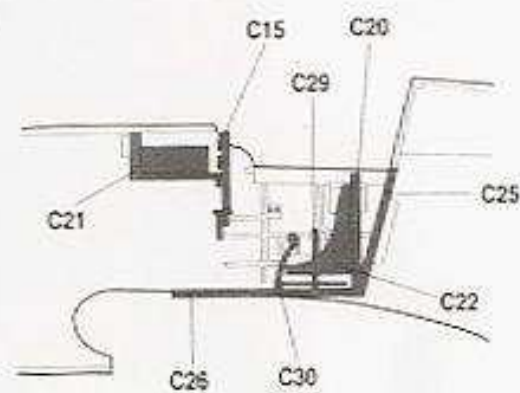
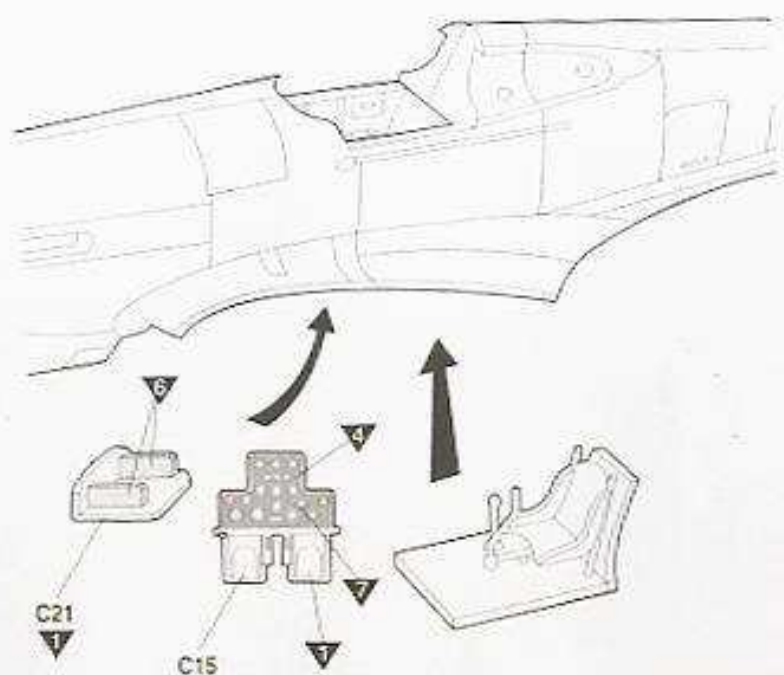

5 

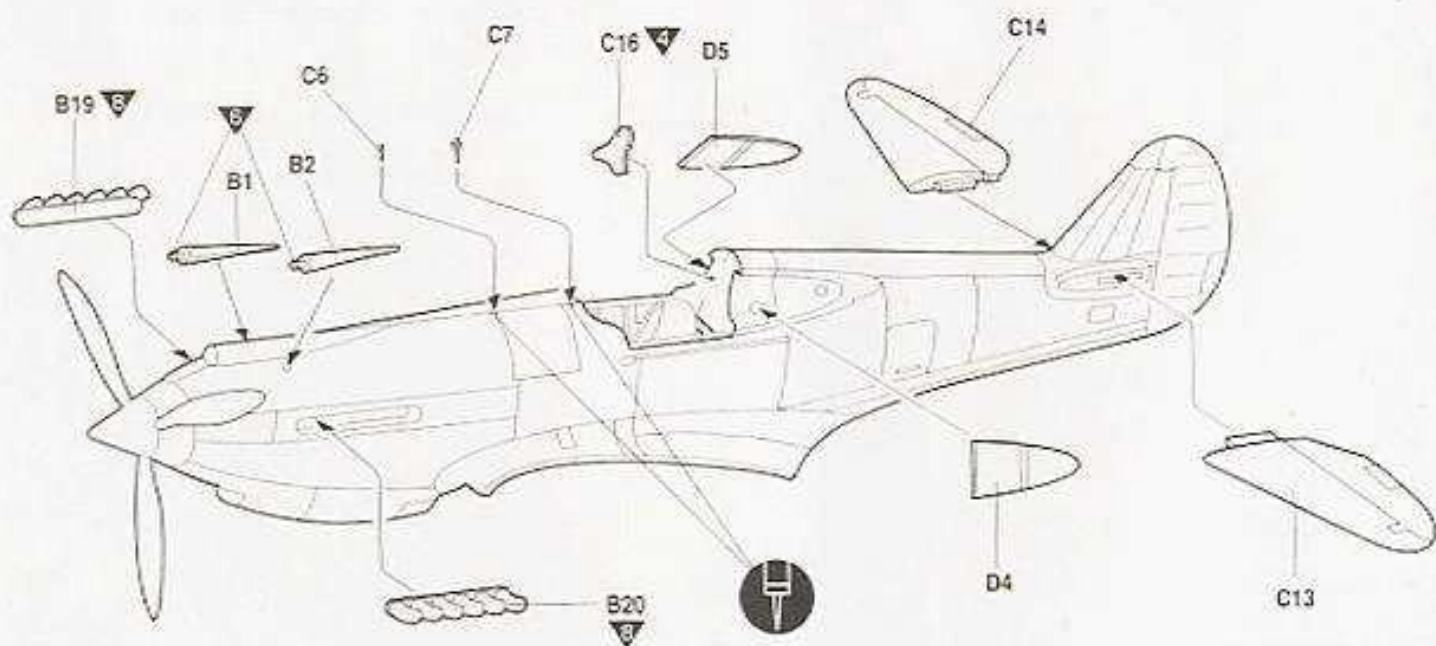

6 

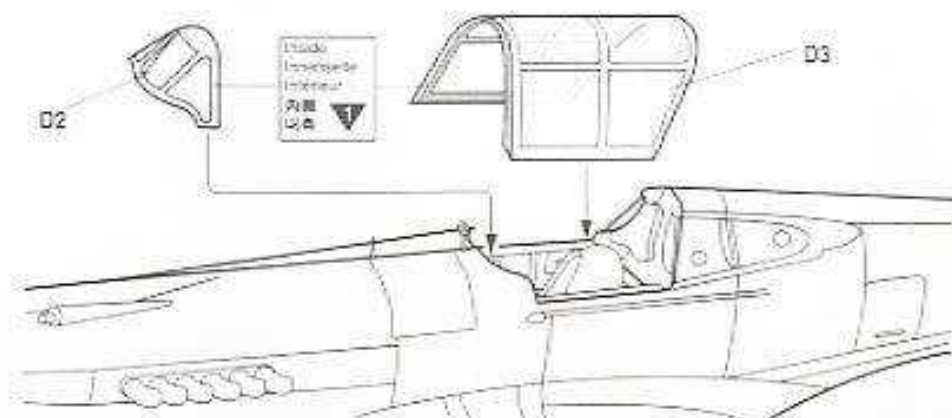

7 

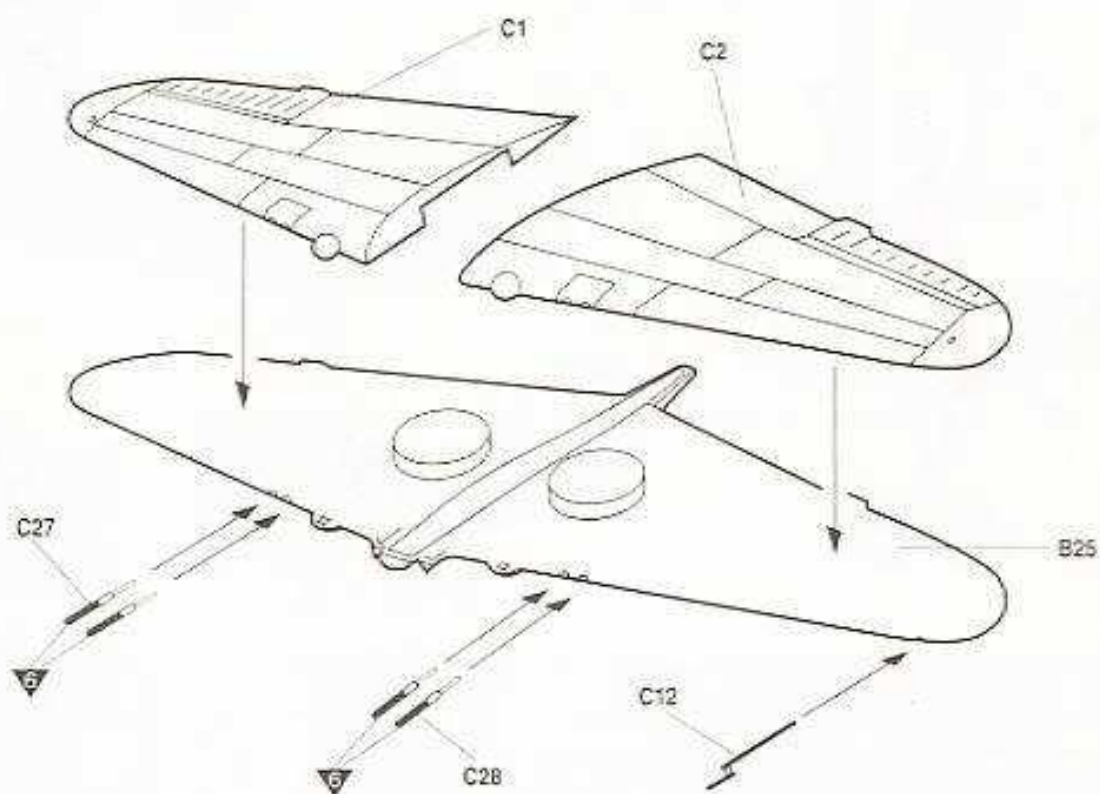

8 

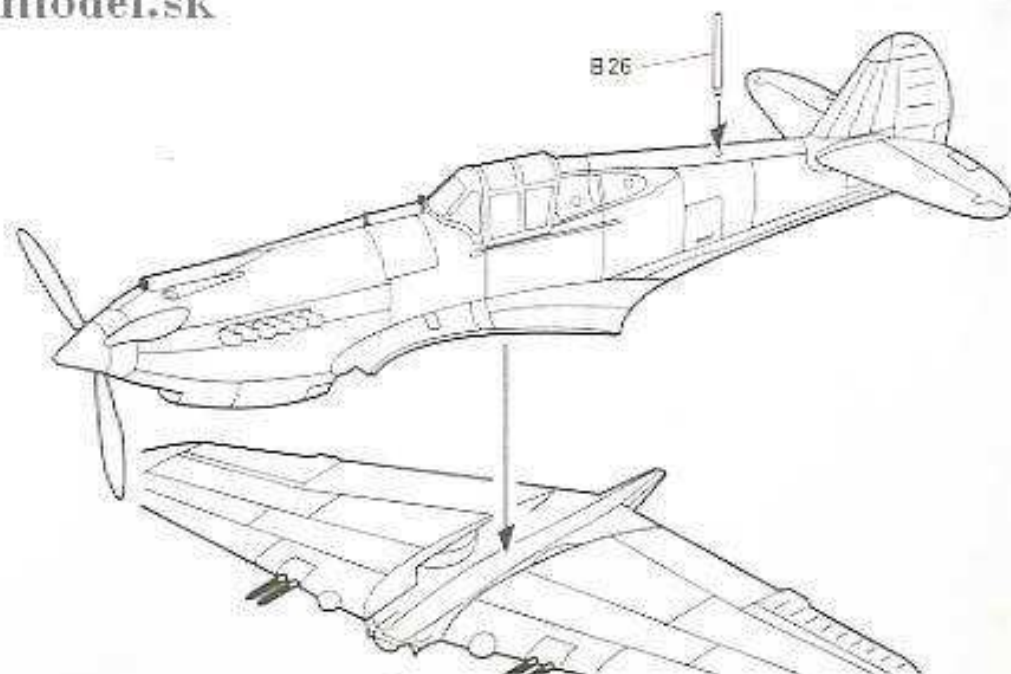

9 

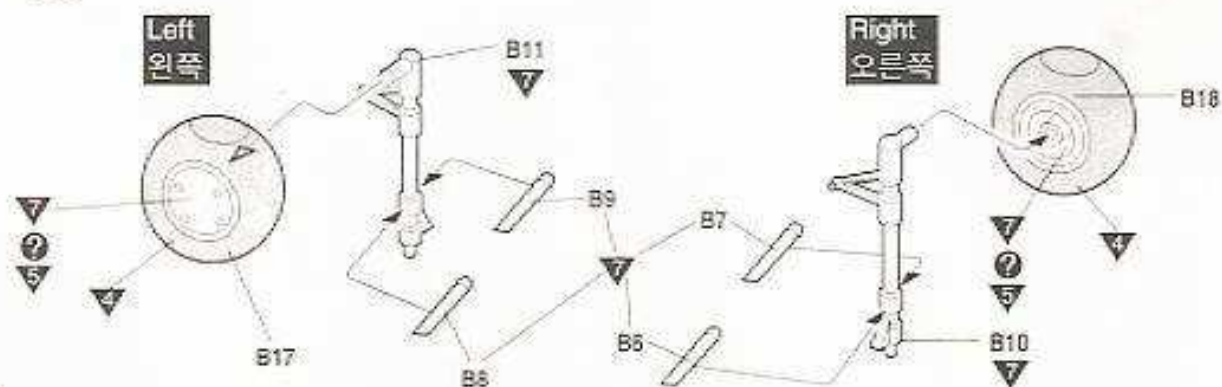

10 

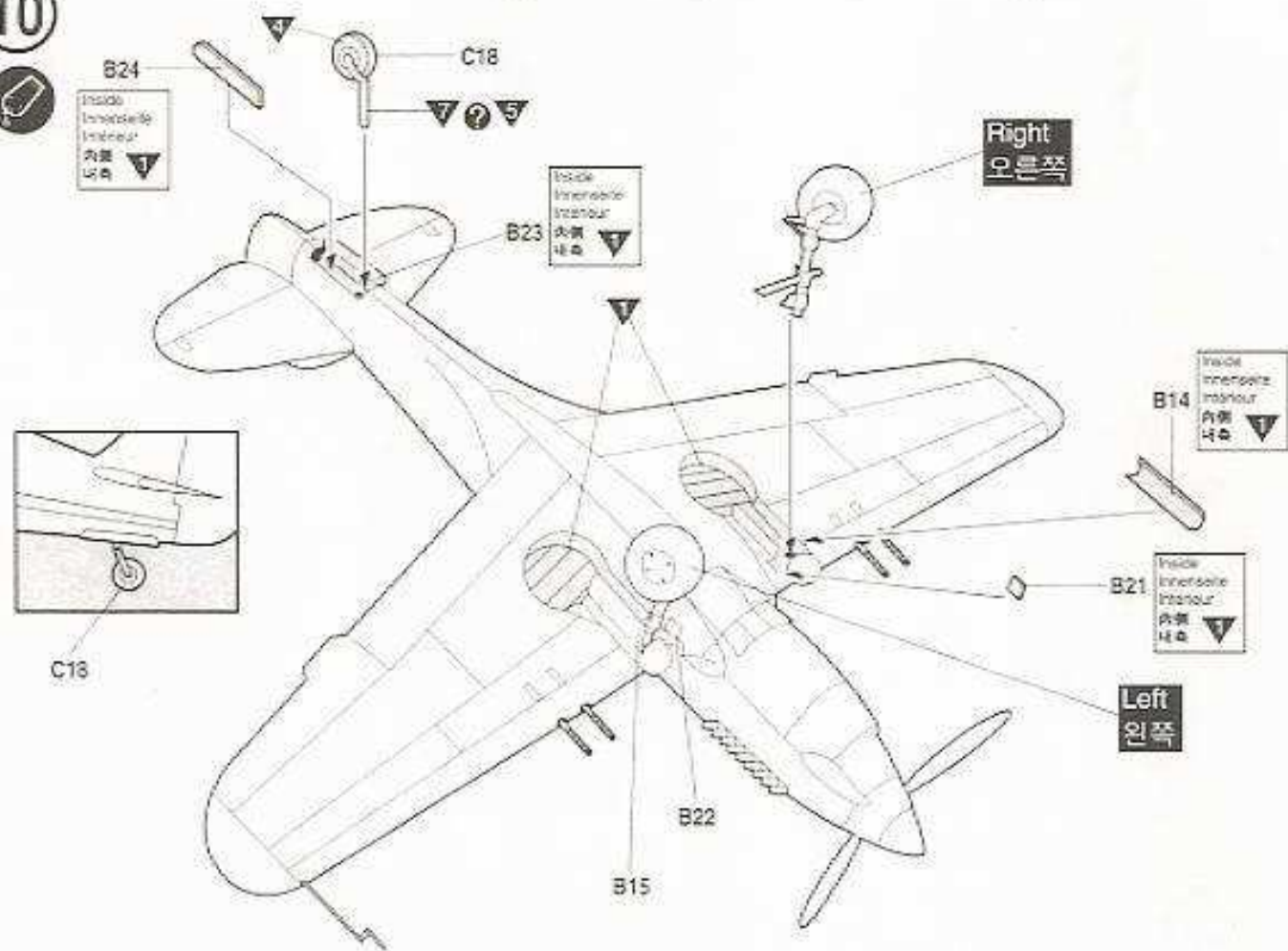

A

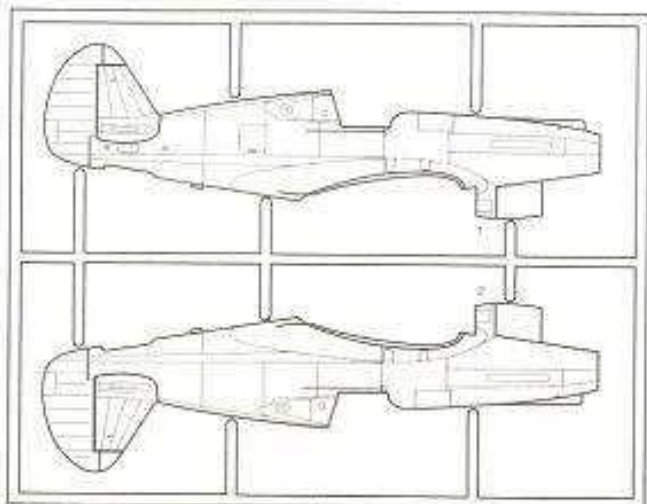

D

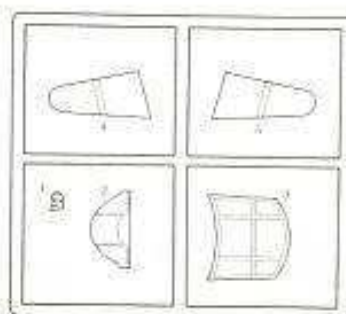

B

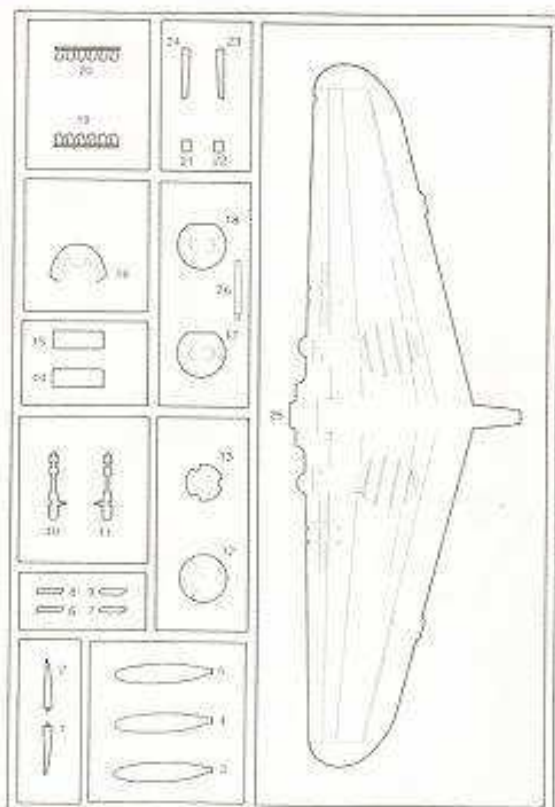

C

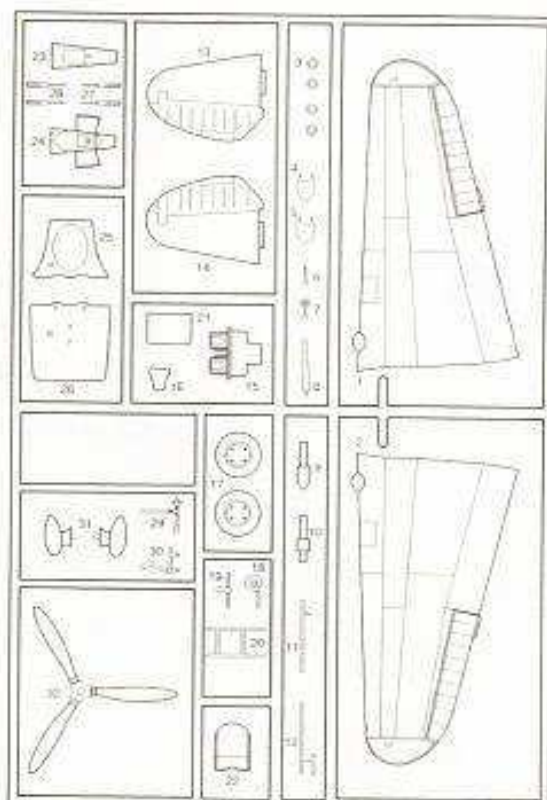

● Decal/전사지

● Unused parts/불필요 부품
C3, C4, C5, C8, C9, C11, C17, C19
C23, C24, C31, C32, D1

- 1** Tomahawk IIb, AN413, RAF Flt Cdr Jack Bartle of No. 112 "SHAR" Sqn, Egypt, Oct. 1941.
 토마호크 IIb AN413, 이집트주둔 영연방공군 제112 "샤르" 비행대대의 적 바틀 소령 탑승기. 1941년 10월.

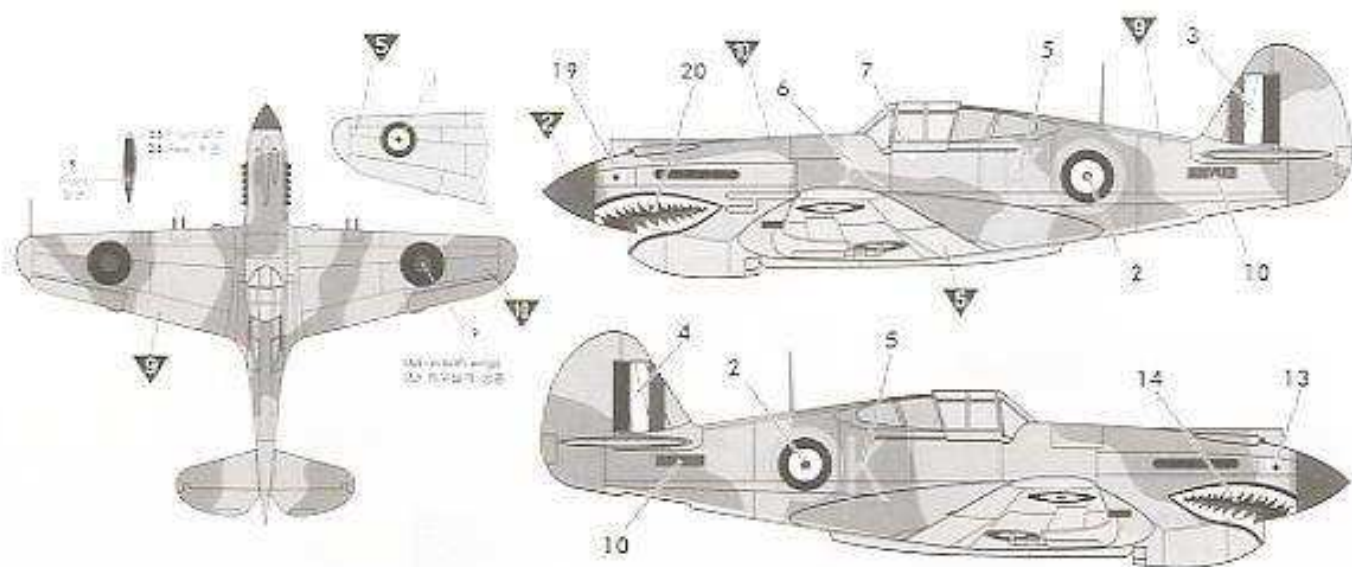

Jack Bartle, Australian Ace with 8 kills promotes to be Flt Lt and No. 112 Sqn, commander after Flt Lt Clive Caldwell in May, 1942. 67 격추기록을 가지는 호주공군의 데이스 적 바틀은 1942년 5월 클리프 칼드웰 소령의 뒤를 이어 소령전과 함께 112비행대의 지휘를 맡는다.

- 2** Tomahawk IIb, AK498, RAF Flt Lt Clive Caldwell of No. 250 "SUDAN" Sqn, Lybia, Nov-Dec. 1941.
 토마호크 IIb AK498, 리비아주둔 영연방공군 제250 "수단" 비행대대의 클리프 칼드웰 소령 탑승기. 1941년 11 - 12월.

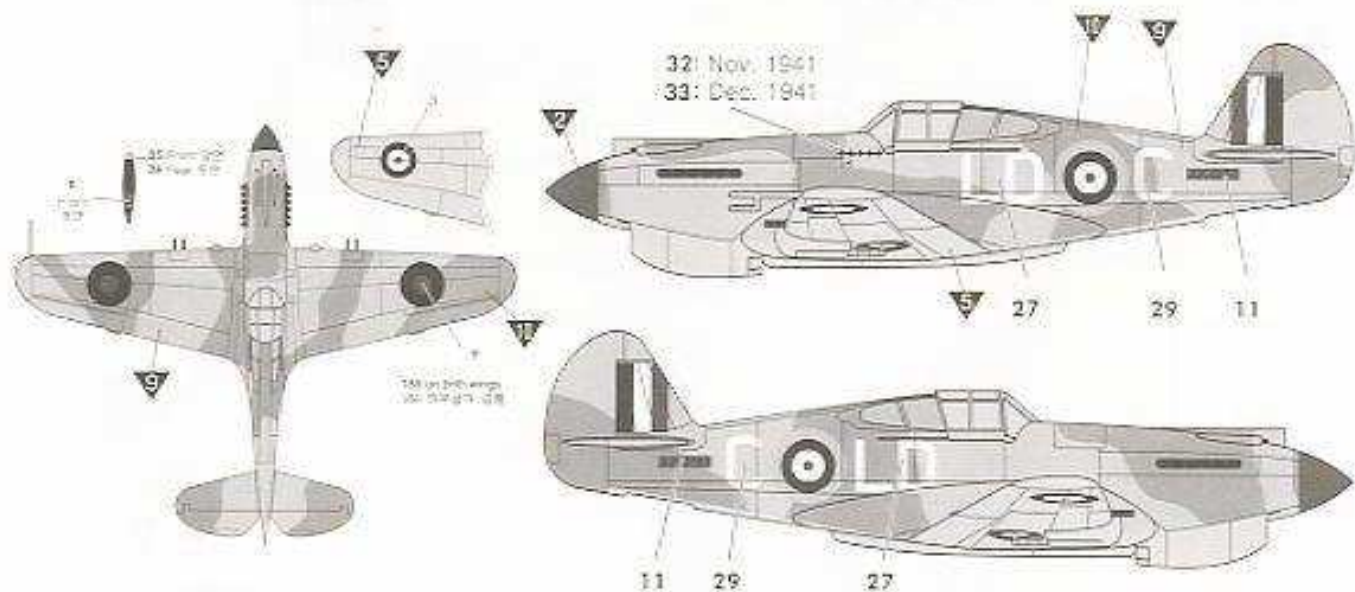

Group Captain Clive Caldwell, an Australian Hero Ace with 28.5 kills, was assigned to Sqn No.250 when he shot down 5 Ju-87 Stukas at one combat in Dec. 1941. In late 1942 he was sent back to RAAF to fight against Japanese threat on Pacific Theatre, flying Spitfires.

최종계급 대령인 클리프 칼드웰 역시 호주공군으로, 호주공군 조종사 가운데 최고기록인 28.5기의 기록을 갖는다. 250비행대 소속으로 리비아의 전투중이던 1941년 12월 5일 한 번의 전투에서 5기의 Ju-87 슈투카를 격추시킨다. 이후 호주공군으로 복귀하여 태평양전쟁에서 스피트파이어로 일본군과 싸웠다.

3 Tomahawk IIb, AK402, RAF Pit Of Neville Duke of No. 112 "SHARK" Sqn, Egypt, Nov 1941.
 토마호크 IIb AK402, 이집트주둔 영연방공군 제112 "샤크" 비행대 소속, 네빌 듀크 소위 탑승기, 1941년 11월.

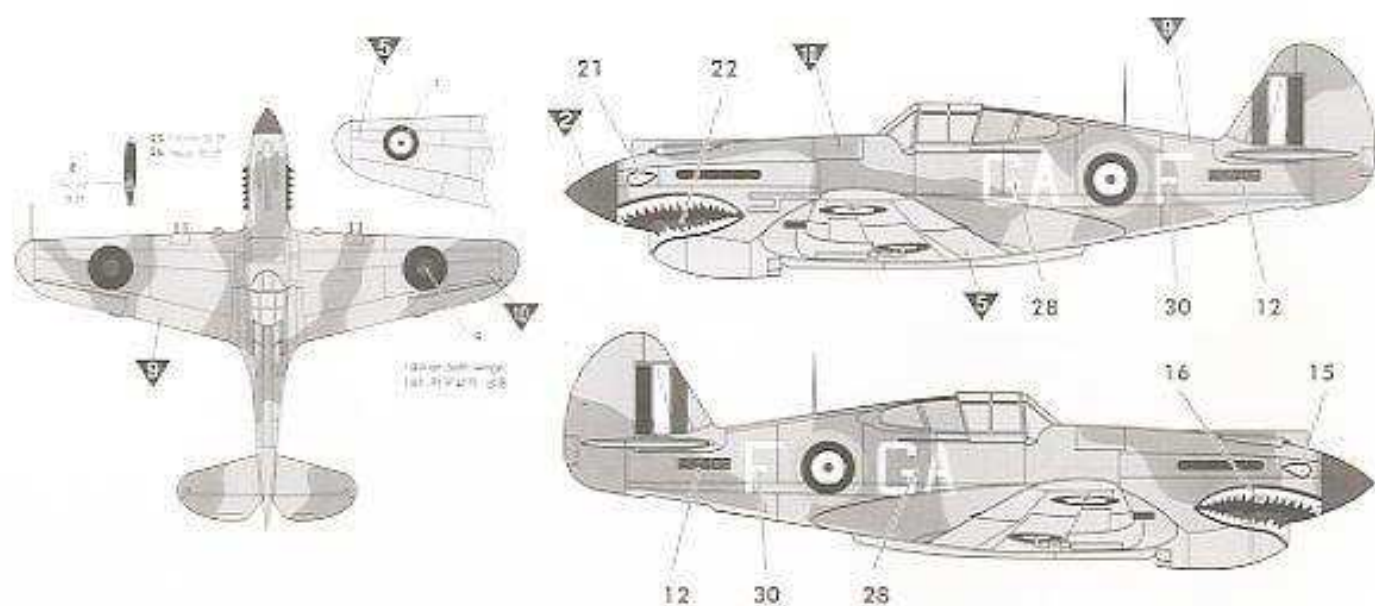

4 Tomahawk IIb, AK578, RAF Pit Of Neville Duke of No. 112 "SHARK" Sqn, Egypt, Jan-Feb. 1942.
 토마호크 IIb AK578, 이집트주둔 영연방공군 제112 "샤크" 비행대 소속, 네빌 듀크 소위 탑승기, 1942년 1~2월.

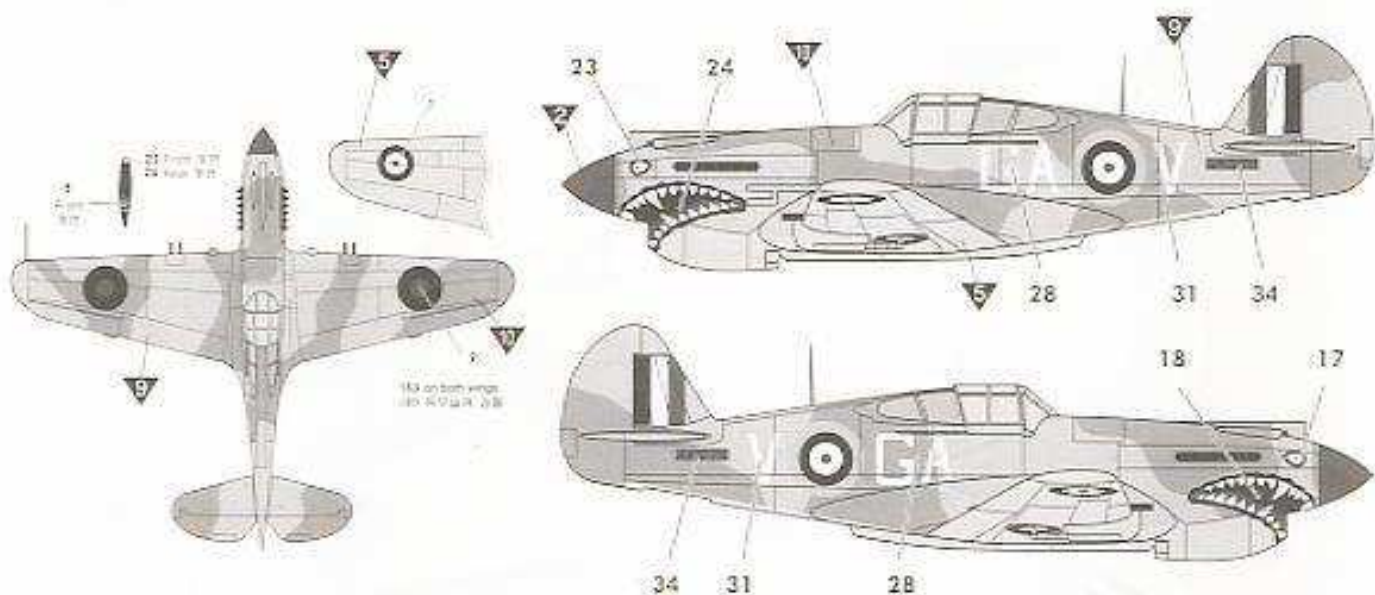

Squadron Leader Neville Fredrick Duke, scoring at least 27, was 19 when he became ace on 30. Nov. 1941 on AK402, finishing the fight by being shot down by German Ace Otto Schulz. He kept flying mainly in AK578 and Kittyhawk, Spitfires, to be a Mediterranean Theatre's top Allied fighter ace. Later he worked for Hawker as a test pilot, recording top speed with Hunter.
 최장기를 더했던 네빌 프레드릭 듀크가 AK402를 조종하며 다섯번째 격추를 기록, 위이스가 되던 1941년 11월 30일 그는 아직 19세였으며, 그 비행은 독일공군의 비이스만 오토 슐츠에게 격추당하는 것으로 끝나버렸다.
 그럼에도 아래의 AK578 및 Kittyhawk, 스피트파이어 등을 조종하며 지중해전선의 연합군 최고 위이스어까지 이른다. 이후 호커사의 시험조종사로 근무하였고, 전투를 조종하여 세계최고속도를 기록하기도 한다.

		AGUEOUS HOBBI COLOR	Mr. COLOR	LIFE COLOR	HUMBROL	TESTOR/MODEL MASTER		
						ENAMEL	ACRYL	
1	INTERIOR GREEN FS 34151		351	UA004		1715	4736	인테리어 그린
2	RED FS 11136	H<327>	327	LC06	19	2041	4714	빨강색
3	YELLOW FS 13536	H<329>	329	LC03	69	2063	4721	노랑색
4	FLAT BLACK	H<12>	33	LC02	33	1749	4768	무광 검정색
5	AZURE BLUE		370	UA098	109	2048		아주르 블루
6	METALLIC GRAY	H<28>	61	LC76	53	1795	4681	메탈릭 그레이
7	SILVER	H<8>	8	LC74	11	1790	4678	은색
8	BURNT IRON	H<38>	61	LC26	53	1795	4681	번트 아이런
9	MIDDLE STONE	H<71>	21	UA097	225	2052		미들 스톤
10	DARK EARTH FS 30118	H<72>	369	UA092	29	2054		다크 어스